

Half Area Filter Press Instruction Manual



Manual No. 207225, Revision E
Instrument No. 207228

fann[®]

Fann Instrument Company

Half Area Filter Press Instruction Manual

©2011 Fann Instrument Company

Houston, Texas, USA

All rights reserved. No part of this work covered by the copyright hereon may be reproduced or copied in any form or by any means (graphic, electronic, or mechanical) without first receiving the written permission of Fann Instrument Company, Houston, Texas, USA.

Printed in USA.



The information contained in this document includes concepts, methods, and apparatus which may be covered by U.S. Patents. FANN[®] reserves the right to make improvements in design, construction, and appearance of our products without prior notice.

FANN[®] and the FANN logo are registered trademarks of Fann Instrument Company in the United States and/or other countries. All other trademarks mentioned in the operating instructions are the exclusive property of the respective manufacturers.

Contact FANN



Phone

TELEPHONE: 281-871-4482
TOLL FREE: 800-347-0450
FAX: 281-871-4358



Mail

Fann Instrument Company
P.O. Box 4350
Houston, Texas, 77210 USA



Location

Fann Instrument Company
15112 Morales Rd Gate 7
Houston, Texas, 77032, USA



Online

www.fann.com
fannmail@fann.com

Table of Contents

1	Introduction.....	5
1.1	Document Conventions	5
2	Safety	6
2.1	Safe Pressurization.....	6
2.2	Waste Disposal.....	6
3	Features and Specifications.....	7
4	Equipment Setup	8
5	Operation.....	9
5.1	Filtration Test Procedure.....	9
5.2	Clean Up	11
5.3	Storage.....	11
5.4	Carbon Dioxide Cartridge Replacement.....	12
6	Test Analysis	13
6.1	References	13
6.2	Results	13
6.3	Filtrate Volume	13
6.4	Filter Cake Thickness	13
7	Preventative Maintenance	14
8	Optional Equipment	15
9	Parts List.....	16
10	Warranty and Returns.....	18
10.1	Warranty.....	18
10.2	Returns.....	18

List of Figures

Figure 3-1 Half Area Filter Press Kit	7
Figure 5-1 End cap and Rubber Boot	9
Figure 5-2 Rubber Boot inside cell	9
Figure 5-3 Half Area Filter Press Cell	10
Figure 9-1 Half Area Filter Press Assembly	17

List of Tables

Table 3-1 Half Area Filter Press, P/N 207228 Specifications	7
Table 8-1 Optional Equipment	15
Table 9-1 Half Area Filter Press, Revision N	16

1 Introduction

Fann's Half Area Filter Press is a compact version of the standard filter press, using one-half the filtration area. The standard filter press is used in a static filtration test to measure fluid loss and filter cake characteristics of drilling fluids. Operators use the Half Area Filter Press in the lab and field.

A static filtration test is conducted at ambient temperature and 100 psi pressure in 30 minutes. Fann's Half Area Filter Press uses carbon dioxide cartridges as the pressure source and specially hardened filter paper over a mesh screen as the filter medium. The filtrate volume (fluid loss) indicates the cake permeability. If the fluid loss is high, then the cake permeability will be high. Measuring filtration behavior and wall-cake building characteristics of a mud is essential to drilling fluids management and treatment.

1.1 Document Conventions

The following icons are used in this manual to distinguish elements of text.



Notes emphasize additional information that may be useful to the reader.



Caution messages give directions that, if not observed, could result in loss of data or in damage to equipment.



Describes an unsafe condition or practice that if not corrected, will result in personal injury, possibly death.

2 Safety

Fann's Half Area Filter Press requires pressurization and filters drilling fluids. Before operating or maintaining this equipment, be aware of the following safety precautions.

2.1 Safe Pressurization

When pressurizing the cell always make sure that the regulator is closed. It is closed when the T-screw is backed all the way out (counterclockwise). Then open the supply pressure and adjust the regulator.

Do not pressurize higher than 100 psi (690 kPa). Follow the procedure as outlined in Section 5.

When carbon dioxide (CO₂) cartridges are the pressure source, no inlet pressure gauge or valve is used.

Use care when replacing spent CO₂ cartridges. There could be some residual pressure in them. Close the cell valve to bleed off the pressure, and then back out the regulator T-screw.



Keep CO₂ cartridges away from extreme heat or direct sunlight.

2.2 Waste Disposal

Safely and properly handle and dispose of drilling fluids.

- Always follow your waste management procedures.
- Always provide your environmental contact with details when new products, chemicals or processes are introduced into the work environment.
- Immediately contain and report any spills or releases of chemicals, products or contaminated materials or wastes.

3 Features and Specifications

The half area filter press consists of a filter cell body (cell) containing a pressurizing inlet, a pressure regulator, and a pressure gauge. When you order the half area filter press, you will also receive the following items:

- Carbon Dioxide Cartridges, 10/box
- Wall Mounting Bracket
- Graduated Cylinder, 100 mL
- Filter Paper, 100/box

A rubber diaphragm (boot) is supplied to contain the drilling fluid and separate it from the pressurizing gas.

A frog mount is attached to the exterior of the cell, and a wall mounting bracket is provided for supporting the filter press on a wall.

Table 3-1 Half Area Filter Press, P/N 207228 Specifications

Category	Specification
Working Pressure	100 psi (690 kPa)
Filtering Area	3.55 in ² (22.58 cm ²)
Dimensions (Width x Depth x Height)	5 x 4 x 3 inches 12.7 x 10.2 x 7.6 centimeters
Weight	4.6 lb (2.1 kg)



Figure 3-1 Half Area Filter Press Kit

4 Equipment Setup

The filter press can generally be arranged to suit the available space and the desires of the lab personnel, consistent with any established work processes.

Consideration should be given to the location where samples are prepared and the cell is cleaned following test completion. There should be sufficient storage area nearby for commonly used tools, as well as consumables, such as filter paper and pressurizing cartridges.

Use the frog mount and a wall mounting bracket to mount the filter press on a wall.

Place the graduated cylinder underneath the cell end cap on the filter press.

5 Operation

This section describes the operations involved in using the Half Area Filter Press. It is organized in the following subsections:

- Filtration Test Procedure
- Clean Up
- Storage

5.1 Filtration Test Procedure

Refer to Figure 5-1, 5-2, and 5-3.

1. Unscrew the end cap from the cell. Make sure that the rubber boot diaphragm is properly seated around its top edge to ensure a tight seal. The top edge of the boot is the gasket that provides the seal to the filter paper and end cap.

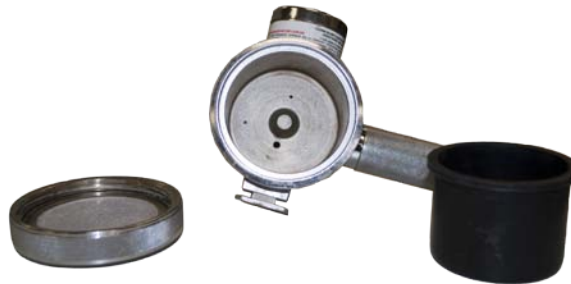

Figure 5-1 End cap and Rubber Boot



Figure 5-2 Rubber Boot inside cell

2. Pour the drilling fluid sample into the boot to within 1/16 inches (1.6 mm) of the top. Place a 6.35-cm filter paper across the top of the boot and screw down the end cap firmly. Hand tightening is sufficient.
3. Holding the cell with the T-screw up and end cap down, mount the cell in the bracket on the wall. Put a 10 ml graduated cylinder directly under the filtrate tube to catch the filtrate.



Figure 5-3 Half Area Filter Press Cell

4. Open the cell valve by pushing it toward the back of the cell. After checking that the regulator adjusting screw is backed out (counterclockwise), remove barrel and insert a CO₂ cartridge. Turn barrel until contact with puncturing pin is felt. Advance an additional one-fourth turn.
5. Rapidly screw the regulator T-screw into the regulator so that 100 ± 5 psi (690 ± 35 kPa) is applied. If this pressure cannot be applied, replace the CO₂ cartridge. See Section 5.4 for those instructions. Otherwise, begin timing.



NOTE

Start timing the test as soon as the proper pressure is applied.

6. After 30 minutes, close the cell valve by pushing it toward the front of the cell. This will also bleed the CO₂ out of the cell and relieve the pressure on the boot.
7. Record the volume of filtrate collected in the cylinder in milliliters (to the nearest 0.1 ml). Correct to the standard API filtration area by multiplying by 2.

**CAUTION**

Be careful when handling the cell when it is filled with drilling fluid, making sure that the valve is not accidentally opened before the end cap is screwed on.

8. With the cell valve closed, unscrew the T-screw to its maximum outward position. Remove the end cap, and discard the drilling fluid sample.
9. Save the filter paper and the filter cake. Handle the filter cake with extreme care, making sure that it stays together.
10. Wash the filter cake on the paper with a gentle stream of water or diesel oil if testing oil based drilling fluids.
11. Measure the thickness of the filter cake. Record the thickness of the filter cake to the nearest 1/32 in. (0.8 mm).
12. Record the cake's consistency using descriptions like hard, soft, tough, rubbery, firm, etc.

5.2 Clean Up

1. Remove the boot and thoroughly clean the boot and the chamber. Thoroughly rinse all filtrate from the screen and filtrate tube. Wipe off the remainder of the filter press. Dry all parts completely.
2. Replace the boot in the cell and screw the end cap back onto the cell.
3. Remount the filter press on the wall.

5.3 Storage

To prepare the filter press for storage, follow these instructions.

**WARNING**

Do not unscrew the barrel from the cell without being certain that the CO₂ cartridge is completely empty.

1. Unscrew the barrel from the cell and remove the CO₂ cartridge.
2. Screw the barrel back into the cell.
3. Unscrew the regulator T-screw to its maximum outward position.

5.4 Carbon Dioxide Cartridge Replacement



Use care when handling CO₂ cartridges. Keep the cartridges away from direct sunlight or heat. The cartridges are not hazardous; however, they should be protected from extreme heat, like the heat from being exposed to direct sunlight.

1. Close the cell valve by pushing it toward the front of the cell. This will bleed the CO₂ out of the cell.
2. Return the regulator T-screw to its maximum outward position.
3. Remove the barrel from the pressure unit. Remove and discard the spent CO₂ cartridge.

6 Test Analysis

6.1 References

- API Recommended Practice for Field Testing Water Based Drilling Fluids, API RP 13B-1/ISO 10414-1
- API Recommended Practice for Field Testing Oil Based Drilling Fluids, API RP 13B-2
- API Recommended Practice Testing Field Cements, API RP 10B-2/ISO 10426-2.

6.2 Results

Measurement of the filtration behavior and wall cake building characteristics of a drilling fluid (mud) is fundamental to drilling fluid control and treatment. The characteristics of the filtrate, such as oil, water, or emulsion content are also important.

These characteristics are affected by the types and quantities of solids in the fluid, and their physical and chemical interactions. Temperature and pressure affect all these characteristics. Therefore, tests are often run at both low pressure and temperature, and elevated pressure and temperature; different equipment and techniques are required.

The fundamental filtration measurements include the filtrate volume and filter cake thickness.

6.3 Filtrate Volume

The volume of liquid filtrate collected after 30 minutes is reported in milliliters (ml), to the nearest 0.1 ml. The test temperature at which the filtrate was produced is also recorded on the appropriate Drilling Mud Report. The filtrate volume for the half area filter press test is calculated by this formula:

$$\text{Filtrate volume (ml)} = 2 \times (\text{volume collected in 30 minutes, ml})$$

6.4 Filter Cake Thickness

The thickness of the resulting filter cake is measured at its center, and reported to the nearest 1/32 inch (0.8 mm).

7 Preventative Maintenance

After each use, the filter press cell should be disassembled and cleaned. Wash and thoroughly rinse with water, making sure that all drilling fluid is removed. Wipe off the rest of the filter press, and dry all parts completely. Assemble the end cap onto the cell. Loosely reassemble the cell onto the frame for storage.

Replace worn or damaged O-rings or gaskets.

8 Optional Equipment

These items are available as optional purchases for use with the filter press.

Table 8-1 Optional Equipment

Part Number	Description
205868	Cylinder, Graduated, 25 ml
206035	Timer, Interval, 30 minute

9 Parts List

Table 9-1 Half Area Filter Press, Revision N

Item No.	Part No.	Quantity	Description
0001	207226	1	CELL BODY
0002	207227	1	CAP END
0003	207229	1	RETAINER SCREEN
0004	205699	1	RETAINER RING E 3/8 IN SHAFT
0005	207232	1	SCREEN 60 MESH
0006	207231	1	DIAPHRAGM / RUBBER BOOT
0007	205648	1	O-RING 5/32 X 1/16 NITRILE B-46 00
0008	208636	1	BUSHING REGULATOR
0009	208637	1	GLAND
0010	208638	1	SPRING VALVE
0011	208634	1	HOLDER SEAT ASSEMBLY (11-1,2,3,4)
0012	208635	1	GASKET
0013	208633	1	NOZZLE REGULATOR
0015	208639	1	RING, SLIP, REGULATOR
0016	208640	1	SPRING ADJUSTING
0017	208641	1	BUTTON, SPRING, REGULATOR
0018	208646	1	CAP REGULATOR w/TEE SCREW
0020	206722	1	O-RING, 5/16 X 9/16, NITRILE B-46 (CO ₂ Adapter Head)
0021	208614	1	ADAPTER HEAD for CO ₂ cartridges
0024	208612	1	BARREL for CO ₂ cartridges
0025	207235	1	GASKET POP VALVE for relief valve
0026	208627	1	BALL, 1/4in. DIAMETER, STAINLESS STEEL
0027	208620	1	SPRING, RELIEF VALVE
0028	207234	1	BODY POP VALVE
0029	207230	1	PISTON VALVE
0030	205698	2	RETAINER RING 1/4in. CRESCENT
0031	205647	2	O-RING, 1/8 X 1/16, NITRILE B-46 006
0032	205608	1	GAUGE 160 PSI, 1.5in. DIAL, 1/8 MNPT BACK CONN
0034	206056	1	FILTER PAPER, API, 2.5 in (6.35cm), 100/Box
0035	207233	1	FROG BRACKET
0141	208632	1	DIAPHRAGM REGULATOR
0142	208629	1	CENTRALIZER, DIAPHRAGM
0143	208630	1	NUT
0144	208631	1	PLATE DIAPHRAGM
0150	204218	1	WARRANTY CARD
0160	204577	1	LABEL WITHOUT BORDER
0170	205869	1	GRADUATED GLASS CYLINDER, 10ml TC
0190	207225	1	INSTRUCTION MANUAL
0200	208608	1	CARBON DIOXIDE CARTRIDGES 10/BOX
0210	209396	1	HOLDING, WALL BRACKET
0220	101983293	1	FANN FILTER CAKE THICKNESS RULER, WEIGHT CONVERSION, PLASTIC, 0.02 IN THICK

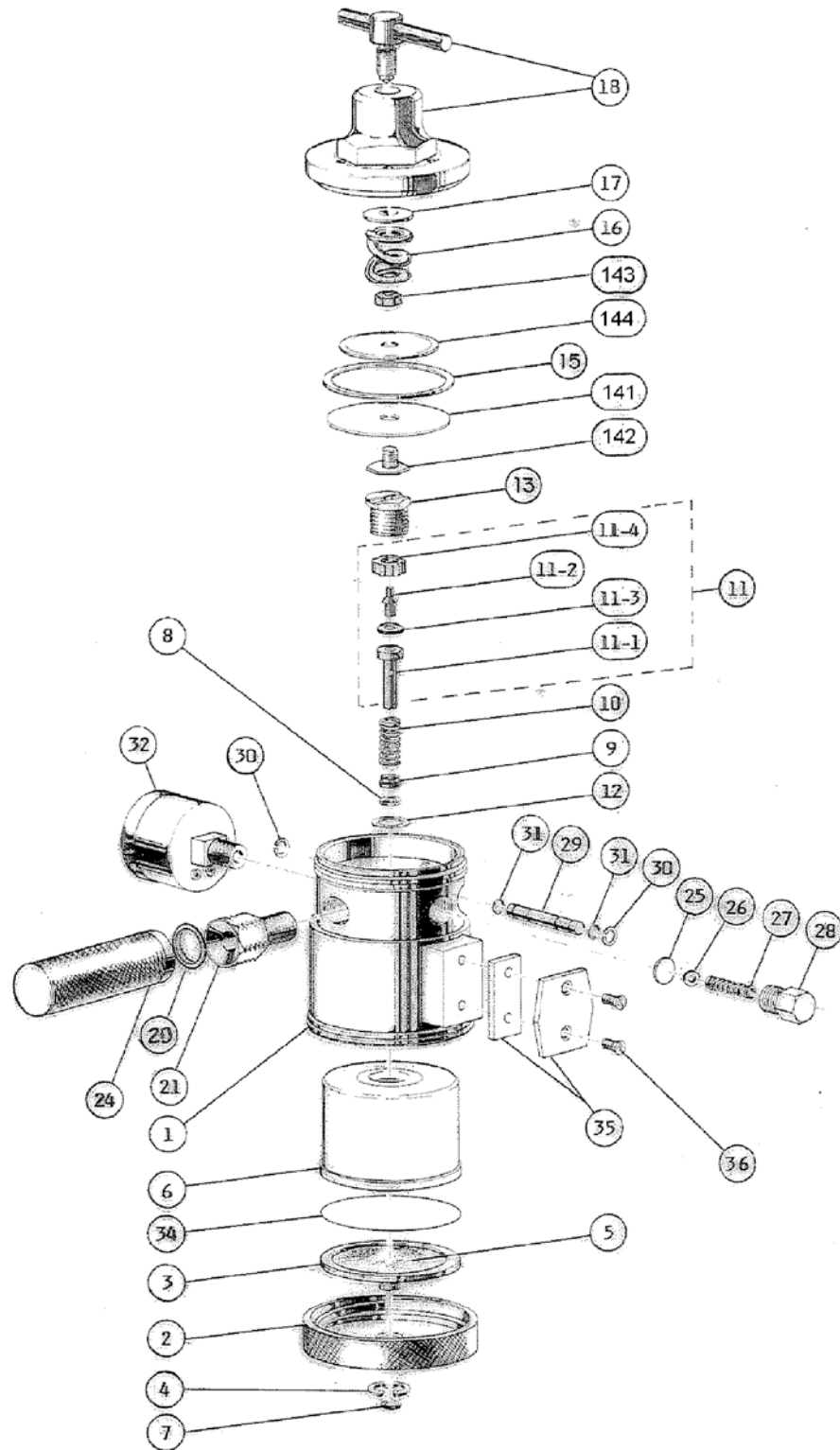

Figure 9-1 Half Area Filter Press Assembly

10 Warranty and Returns

10.1 Warranty

Fann Instrument Company warrants its products to be free from defects in material and workmanship for a period of 12 months from the time of shipment. If repair or adjustment is necessary, and has not been the result of abuse or misuse within the twelve-month period, please return, freight prepaid, and correction of the defect will be made without charge.

Out of warranty products will be repaired for a nominal charge.

Please refer to the accompanying warranty statement enclosed with the product.

10.2 Returns

For your protection, items being returned must be carefully packed to prevent damage in shipment and insured against possible damage or loss. Fann will not be responsible for damage resulting from careless or insufficient packing.

Before returning items for any reason, authorization must be obtained from Fann Instrument Company. When applying for authorization, please include information regarding the reason the items are to be returned.

Our correspondence address is:

Fann Instrument Company

P.O. Box 4350

Houston, Texas USA 77210

Telephone: 281-871-4482

Toll Free: 800-347-0450

FAX: 281-871-4446

Email fannmail@fann.com

Our shipping address is:

Fann Instrument Company

15112 Morales Road

Gate 7, Houston, Texas USA 77032