

Mincon 6DH-LV

Why Buy the Mincon 6DH-LV?

The Mincon 6DH-LV has proven itself the best hammer on the market in all kinds of demanding conditions and applications with low volumes of air available. The Mincon 6DH-LV delivers superior penetration rates versus other manufacturers with extremely smooth drilling.

Like all Mincon DTH hammers, the Mincon 6DH-LV maintains excellent operating pressure over an extended service life and overall is the tool you require to get the maximum out of all your equipment.

Mincon Products are all manufactured in house, and all processes are carried out under the one roof. This guarantees that the quality you “Expect” is always delivered.

Design Highlights:

- ▶ Design allows for increased penetration against large volumes of water, and also allows for the introduction of more water in unstable conditions.
- ▶ Multiple splined shank reduces possibility of shankage.
- ▶ Unique manufacturing processes extend internal components life allowing for multiple rebuilds in abrasive conditions.
- ▶ Valveless operation to maximize energy output, provide efficient air utilization and reduce service requirements.
- ▶ Extra air-flow system allows for better hole cleaning in troublesome holes.
- ▶ Reversible hardened wear sleeve for optimum wear resistance even in the most abrasive conditions.
- ▶ Multi-start threads on backhead and chuck ensure easy coupling/uncoupling of hammer.
- ▶ Unique internal mount system gives positive make-up and eliminates the need for wear shims and special assembly tools.
- ▶ All critical internal components are heat treated under strict control to maximize tool longevity.
- ▶ An overall cost-effective and user friendly tool for use in the most demanding conditions.



Mincon 6DH-LV

Applications:

- Water Well
- Exploration
- Construction

‘The Driller’s Choice’

“LEADERS IN THE FIELD OF DRILLING TECHNOLOGY”

MINCON 6DH-LV PARTS LIST & SPECIFICATION

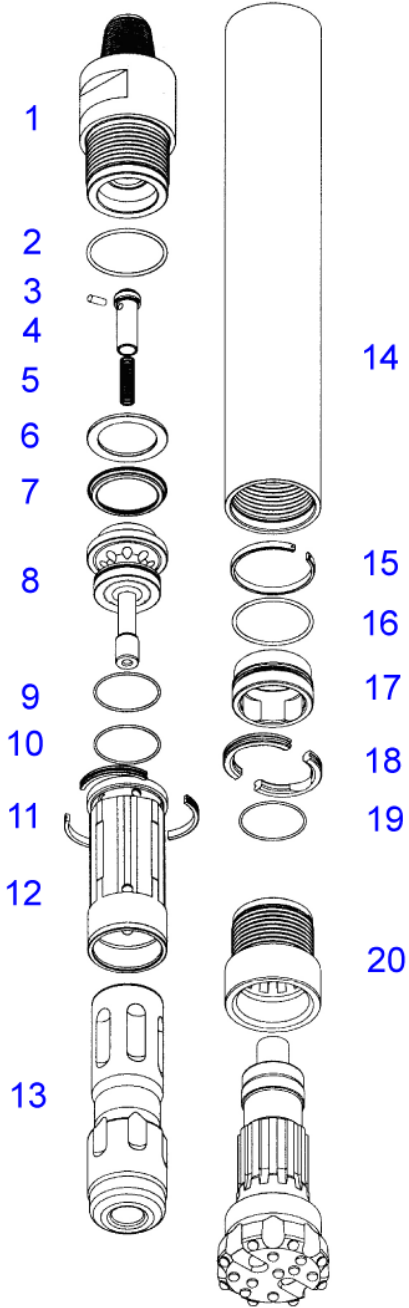

Item	Description	Part No.
	Mincon 6DH-LV Hammer	MD601AS02
1	Backhead	MD601BH01
2	O Ring	MD622OR01
3	Choke Blank	MB506CH01
	Choke 1/8" (3.2mm)	MB506CH02
	Choke 3/16" (4.8mm)	MB506CH03
4	Check Valve	MB502CV01
5	Spring	MB503SP01
6	Steel Make Up Ring	MD604SM01
7	Lock Ring	MD605LR01
8	Air Distributor	MD607DR02
9	O Ring	MD621OR01
10	O Ring	MD620OR01
11	Seating Ring	MD609SR01
12	Inner Cylinder	MD608IC01
13	Piston	MD610PN01
14	Wear Sleeve	M611WS01
15	Piston Retaining Ring	MD612PR01
16	O Ring	MD622OR01
17	Aligner	MB613BB01
18	Bit Retaining Ring	MD614BR01
19	O Ring	MD621OR01
20	Chuck	MD615CK02
Outside Diameter		5.5" / 140mm
Minimum Bit Size		6" / 152mm
Spanner Flat Size		4" / 100mm
Length (Less Bit, Backhead Shoulder to)		40.6" / 1033mm
Bit Shank Type		QL60
Backhead Thread		3 1/2" A.P.I. Reg. Pin
Piston Weight		44 Lbs / 20 Kgs
Wear Sleeve Discard Limit		5.060" / 128.5mm

OPERATING PRESSURE / AIR CONSUMPTION

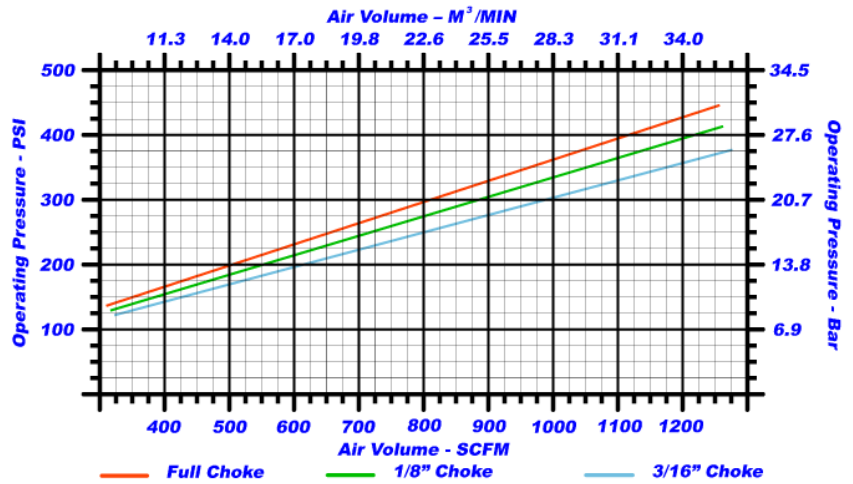

Mincon International Ltd

Shannon, Co. Clare
Ireland

Telephone: +353 61 361 099

Fax: +353 61 361 808

Email: mincon@mincon.com

Web: <http://www.mincon.com>

Distributed by:

ROCKDRILL OIL GRADE

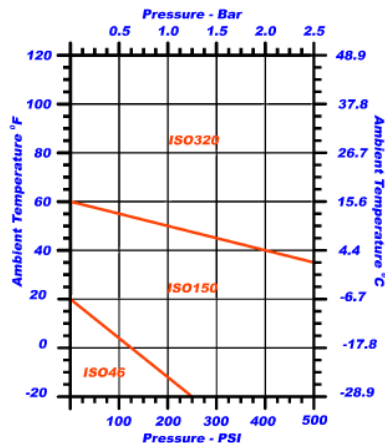

ROCKDRILL OIL CONSUMPTION

