

Mincon 5DH

Why Buy the Mincon 5DH?

The Mincon 5DH is an excellent deep hole hammer that stands up to the rugged tests that are thrown at it. It is a field proven technology that delivers superior penetration rates versus other manufacturers.

Like all Mincon DTH hammers, the Mincon 5DH maintains excellent operating pressure over an extended service life and overall is the tool you require to get the maximum out of all your equipment.

Mincon Products are all manufactured in house, and all processes are carried out under the one roof. This guarantees that the quality you “Expect” is always delivered.

Design Highlights:

- ▶ Patented features maximize energy output and reduce service requirements.
- ▶ Fewer internal components minimize service requirements.
- ▶ Valveless, high frequency design ensures smooth operation.
- ▶ Hardened wear sleeve for optimum wear resistance even in the most abrasive conditions.
- ▶ Multi-start threads on backhead and chuck ensure easy coupling/uncoupling of hammer.
- ▶ Unique internal mount system eliminates the need for wear shims and special assembly tools.
- ▶ All critical internal components are heat treated under strict control to maximize tool longevity.
- ▶ An overall cost-effective and user friendly tool for use in the most demanding conditions.

Mincon 5DH

Applications:

- Water Well
- Geothermal
- Shallow Oil & Gas
- Exploration
- Construction
- Environmental



‘The Driller’s Choice’

“LEADERS IN THE FIELD OF DRILLING TECHNOLOGY”

MINCON 5DH PARTS LIST & SPECIFICATION

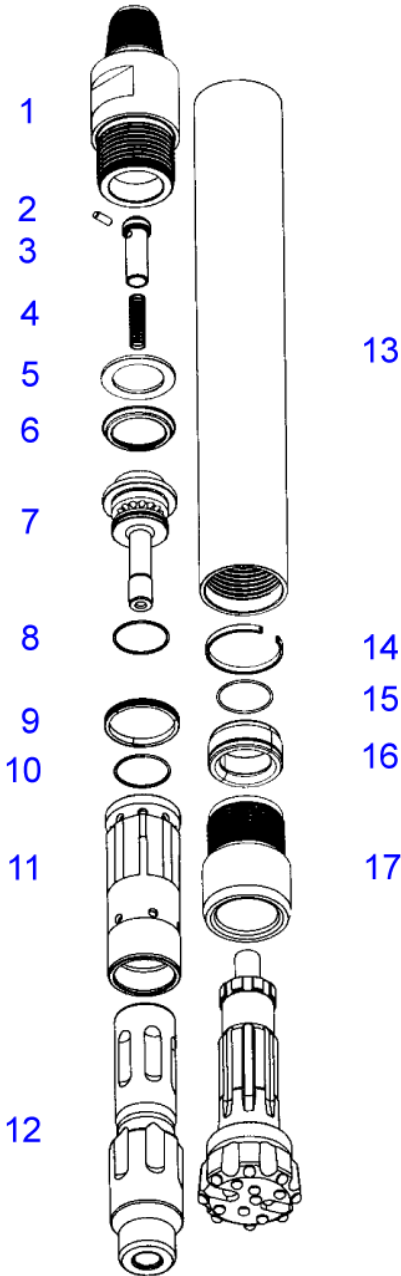

Item	Description	Part No.
	Mincon 5DH Hammer	MDX501AS04
1	Backhead	MDX501BH01
2	Choke Blank	MB506CH01
	Choke 1/8" (3.2mm)	MB506CH02
	Choke 3/16" (4.8mm)	MB506CH03
3	Check Valve	MB502CV01
4	Spring	MB503SP01
5	Steel Make Up Ring	MB504SM01
6	Lock Ring	MB505LR01
7	Air Distributor	MB507DR01
8	O Ring	MB521OR01
9	Seating Ring	MB509SR01
10	O Ring	MB523OR01
11	Inner Cylinder	MD508IC01
12	Piston	MD510PN02
13	Wear Sleeve	MDX511WS03
14	Piston Retaining Ring	MD511PR01
15	O Ring	MB520OR01
16	Bit Retaining Ring	MB513BR01
17	Chuck	MDX514CK01
Outside Diameter		4.88"
Minimum Bit Size		124mm
Spanner Flat Size		5.5"
Length (Less Bit, Backhead Shoulder to Chuck)		140mm
Length (Less Bit, Backhead Shoulder to Chuck)		3.5"
		89mm
Bit Shank Type		41.5"
		1054mm
Bit Shank Type		DHD350R
Backhead Thread		3 1/2" A.P.I. Reg. Pin
Piston Weight		33.6 Lbs
		15 Kgs
Wear Sleeve Discard Limit		4.400"
		111.8mm

OPERATING PRESSURE / AIR CONSUMPTION

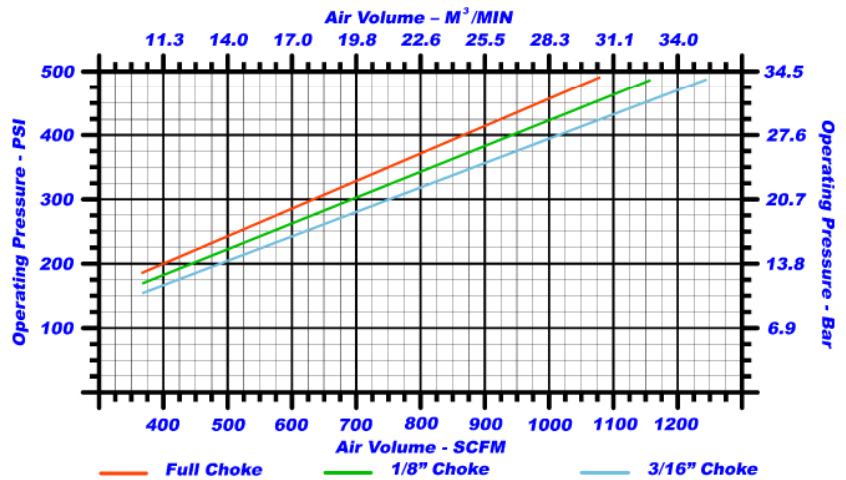

Mincon International Ltd

Shannon, Co. Clare

Ireland

Telephone: +353 61 361 099

Fax: +353 61 361 808

Email: mincon@mincon.com

Web: <http://www.mincon.com>

Distributed by:

ROCKDRILL OIL GRADE

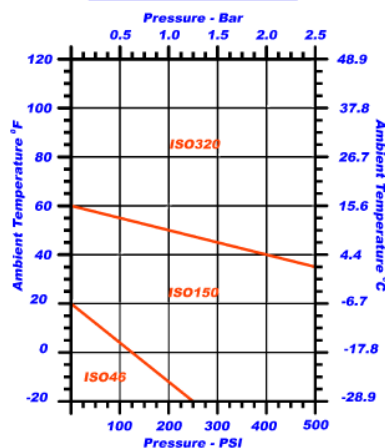

ROCKDRILL OIL CONSUMPTION

