

Mincon 4HR

Why Buy the Mincon 4HR?

The Mincon 4HR is a Universal hammer that can be used in almost any drilling application. It is a field proven technology that delivers superior penetration rates versus other manufacturers. It is an excellent tool for soft, medium and hard rock conditions.

Like all Mincon DTH hammers, the Mincon 4HR maintains excellent operating pressure over an extended service life and overall is the tool you require to get the maximum out of all your equipment.

Mincon Products are all manufactured in house, and all processes are carried out under the one roof. This guarantees that the quality you “Expect” is always delivered.

Design Highlights:

- ▶ Patented features maximize energy output and reduce service requirements.
- ▶ Fewer internal components minimize service requirements.
- ▶ Valveless, high frequency design ensures smooth operation.
- ▶ Hardened wear sleeve for optimum wear resistance even in the most abrasive conditions.
- ▶ Multi-start threads on backhead and chuck ensure easy coupling/uncoupling of hammer.
- ▶ Unique internal mount system eliminates the need for wear shims and special assembly tools.
- ▶ All critical internal components are heat treated under strict control to maximize tool longevity.
- ▶ An overall cost-effective and user friendly tool for use in the most demanding conditions.



Mincon 4HR

Applications:

- Blast Hole
- Underground Mining
- Environmental
- Exploration
- Construction

‘The Driller’s Choice’

“LEADERS IN THE FIELD OF DRILLING TECHNOLOGY”

MINCON 4HR PARTS LIST & SPECIFICATION

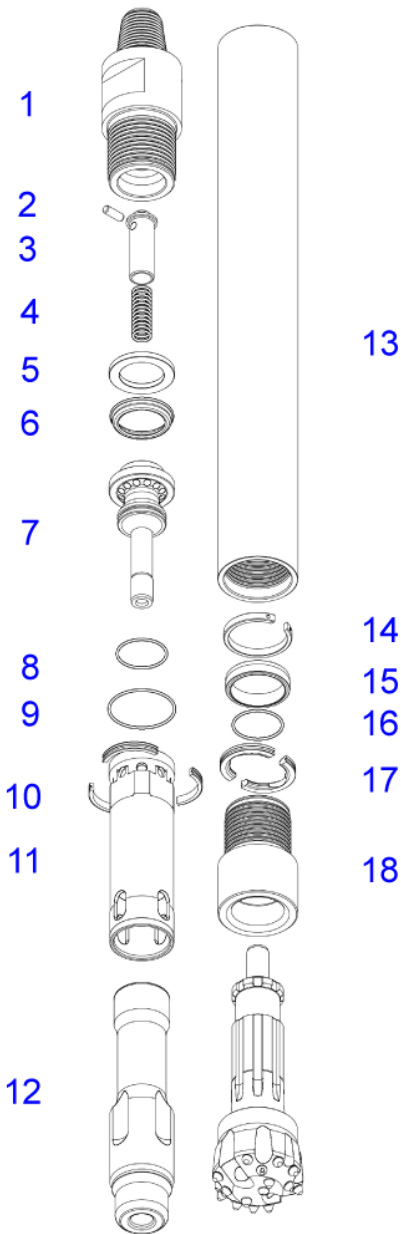

Item	Description	Part No.
	Mincon 4HR Hammer	MD401AS05
1	Backhead	MD401BH03
2	Choke Blank	MB506CH01
	Choke 1/8" (3.2mm)	MB506CH02
	Choke 3/16" (4.8mm)	MB506CH03
3	Check Valve	MB502CV01
4	Spring	MB503SP01
5	Steel Make Up Ring	MD404SM01
6	Lock Ring	MD405LR01
7	Air Distributor	MD407DR03
8	O Ring	MD421OR01
9	O Ring	MD422OR01
10	Seating Ring	MD409SR01
11	Inner Cylinder	MD408IC02
12	Piston	MD410PN03
13	Wear Sleeve	MD411WS02
14	Piston Retaining Ring	MD412PR01
15	Bit Retaining Spacer	MD416BS01
16	O Ring	MD420OR01
17	Bit Retaining Ring	MD413BR06
18	Chuck	MD414CK03
Outside Diameter		3.82" 97mm
Minimum Bit Size		4.33" 110mm
Spanner Flat Size		2.5" 64mm
Length (Less Bit, Backhead Shoulder to Chuck)		37.6" 956mm
Bit Shank Type		DHD340A
Backhead Thread		2 3/8" A.P.I. Reg. Pin
Piston Weight		16.3 Lbs 7.4 Kgs
Wear Sleeve Discard Limit		3.425" 87mm

OPERATING PRESSURE / AIR CONSUMPTION

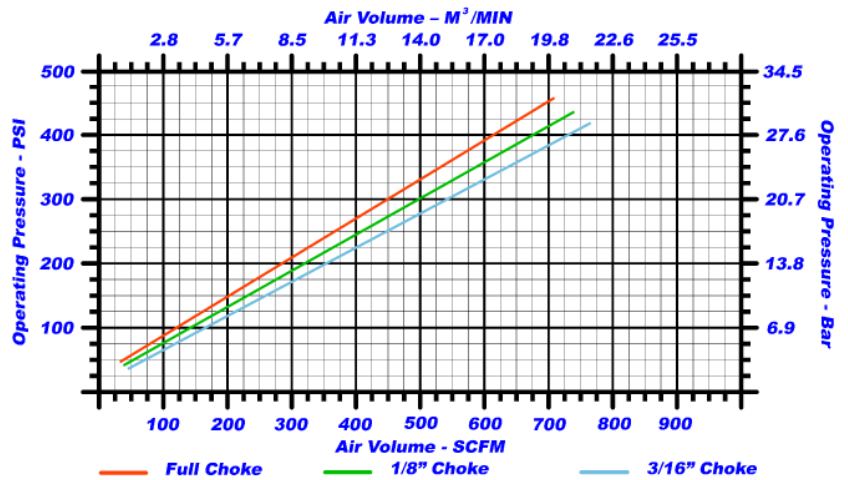

Mincon International Ltd

Shannon, Co. Clare

Ireland

Telephone: +353 61 361 099

Fax: +353 61 361 808

Email: mincon@mincon.com

Web: <http://www.mincon.com>

Distributed by:

ROCKDRILL OIL GRADE

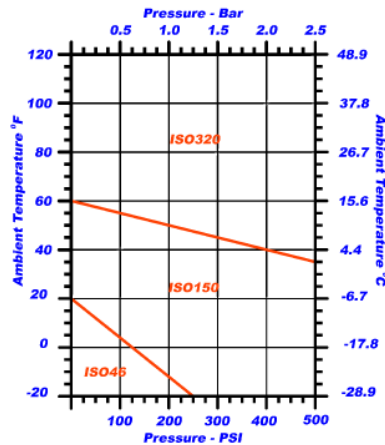

ROCKDRILL OIL CONSUMPTION

