

T8-STD-Hammer

TAKES 380 SHANKS

Thread Change/Pin
Box Thread
Carbide Buttons
Special Flats
Side Carbide Buttons

**SPECIAL BACKHEAD FEATURES—CALL OFFICE

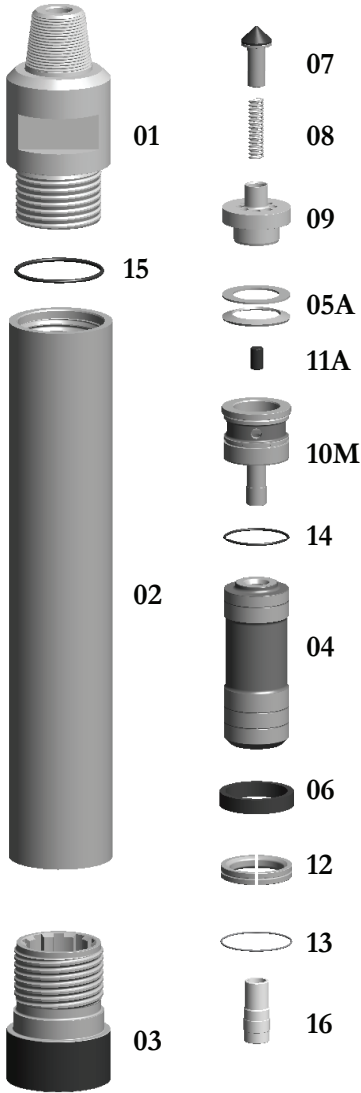

Replacement Parts

Hmr Part #	Description	Order #	Weight (lbs.)
T8-01	Top Sub w/4-1/2" API REG PIN w/O-Ring	EBB8-01	93.0
T8-15	**Replacement O-Ring for Top Sub**	E8-15	0.1
T8-02	Piston Case w/Retainer Ring	ET8-02	142.0
T8-06	**Replacement Retainer Ring for Piston Case**	ET8-06	0.3
T8-03	Chuck	E8-03	36.0
T8-04	Piston	ET8-04	70.0
T8-05A	Disc Spring / Spacer Ring Set	E8-05A	1.5
T8-07	Check Valve Dart	E8-07	1.5
T8-08	Check Valve Dart Spring	E8-08	0.3
T8-09	Check Valve Guide	E8-09	12.0
T8-10M	Rigid Valve w/O-Ring	E8-10M	15.0
T8-14	**Replacement O-Ring for Rigid Valve**	E8-14	0.1
T8-11	Choke Set	E8-11(5)	1.5
T8-11A	Blank Choke	E8-11A	0.3
T8-11B	1/8" Choke	E8-11B	0.3
T8-11C	1/4" Choke	E8-11C	0.3
T8-11D	3/8" Choke	E8-11D	0.3
T8-11E	7/16" Choke	E8-11E	0.3
T8-12	Bit Retainer Ring w/O-Ring	ET8-12	3.0
T8-13	**Replacement O-Ring for Bit Retainer**	ET8-13	0.1
T8-16	Foot Valve	ET8-16	0.2
T8-17	Brass Break Out Ring (Optional) Top	E8-17	0.2
T8-17A	Brass Break Out Ring (Optional) Bottom	ET8-17	0.2

	Outside Diameter		Hammer Length Pin		Hammer Length Box		Bit Size Range				
	IN.	MM.	IN.	MM.	IN.	MM.	IN.	MM.			
TH8	7-1/8	180.34	52-3/8	1330.5	52-7/8	1343	7-7/8-12	200-305			
Choke Size	150 PSI	10.3 BARS	200 PSI	13.8 BARS	250 PSI	17.2 BARS	300 PSI	20.7 BARS	350 PSI	24.1 BARS	
IN.	MM.										
Blank	Blank	550	15.57	734	20.78	917	29.97	1101	31.18	1285	36.39
1/8	3.18	575	16.28	764	21.63	957	27.1	1151	32.59	1345	38.08
1/4	6.35	630	17.84	824	23.33	1022	28.94	1286	36.42	1495	42.34
3/8	9.53	750	21.24	999	28.29	1242	35.17	1485	42.05	1715	48.57
7/16	11.11	840	23.96	1104	31.26	1372	38.85	1626	46.04	1885	53.37
1/2-None	12.70	940	26.62	1214	34.38	1487	42.11	1771	50.15	2065	58.47

The above air charts are based upon ideal conditions, your results may vary.