

E8-STD-Hammer

TAKES SD8 SHANKS

Thread Change/Pin
Box Thread
Carbide Buttons
Side Carbide Buttons
Special Flats

**SPECIAL BACKHEAD FEATURES—CALL OFFICE

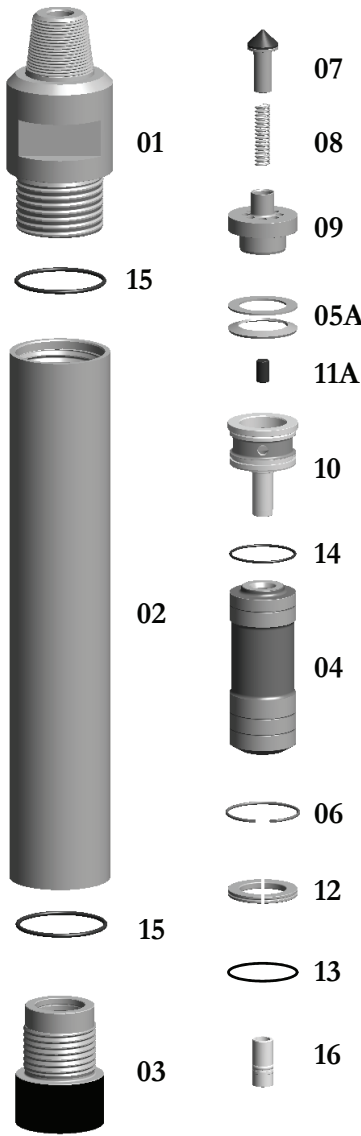

Replacement Parts

Hmr Part #	Description	Order #	Weight (lbs.)
8-01	Top Sub 4-1/2" API REG PIN w/O-Ring	E8-01	87.0
8-15	**Replacement O-Ring for Top Sub**	E8-15	0.1
8-02	Piston Case w/Retainer Ring	E8-02	127.0
8-06	**Replacement Retainer Ring for Piston Case**	E8-06	0.3
8-03	Driver Sub w/O-Ring	E8-03	40.0
8-15	**Replacement O-Ring for Driver Sub**	E8-15	0.1
8-04	Piston	E8-04	71.0
8-05A	Disc Spring & Spacer Set	E8-05A	1.5
8-07	Check Valve Dart	E8-07	1.5
8-08	Check Valve Dart Spring	E8-08	0.3
8-09	Check Valve Guide	E8-09	12.0
8-10	Rigid Valve w/O-Ring	E8-10	14.0
8-10M	Rigid Valve w/O-Ring - Modified	E8-10M	15.0
8-14	**Replacement O-Ring for Rigid Valve**	E8-14	0.1
8-11	Choke Set	E8-11(5)	1.5
8-11A	Blank Choke	E8-11A	0.3
8-11B	1/8" Choke	E8-11B	0.3
8-11C	1/4" Choke	E8-11C	0.3
8-11D	3/8" Choke	E8-11D	0.3
8-11E	7/16" Choke	E8-11E	0.3
8-12	Bit Retainer Ring w/O-Ring	E8-12	1.6
8-13	**Replacement O-Ring for Bit Retainer**	E8-13	0.2
8-16	Foot Valve	E8-16	0.9
8-17	Brass Break-Out Ring (Optional)	E8-17	0.1

	Outside Diameter		Hammer Length Pin			Hammer Length Box		Bit Size Range		
	IN.	MM.	IN.	MM.	IN.	MM.	IN.	MM.		
Drill 8	6-3/4	172	47-1/16	1195.4	51-5/16	1303.3	7-3/8-12	188-305		
Choke Size	150 PSI	10.3 BARS	200 PSI	13.8 BARS	250 PSI	17.2 BARS	300 PSI	20.7 BARS	350 PSI	24.1 BARS
Blank	Blank	440	625	17.70	810	22.94	985	27.90	1160	32.85
1/8	3.18	465	655	18.55	850	24.07	1035	29.31	1220	34.55
1/4	6.35	520	715	20.25	955	27.05	1160	32.85	1370	38.80
3/8	9.53	640	890	25.20	1135	32.14	1365	38.66	1590	45.03
7/16	11.11	730	995	28.18	1265	35.82	1510	42.76	1760	49.84
1/2-None	12.70	830	1105	31.29	1380	39.08	1655	46.87	1940	54.94

The above air charts are based upon ideal conditions, your results may vary.