



HYPER 63 DTH HAMMER

Technical Brochure



Certificate Number 2446/00
ISO9001

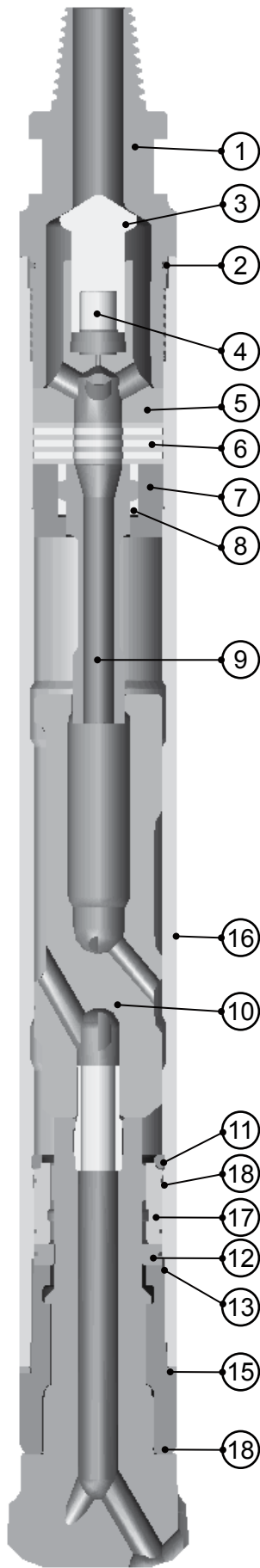

Hyper 63 Valveless Hammer

152mm (6") - 216mm (8½") diameter holes

The Hyper 63 is a valveless D.T.H Hammer designed for drilling 152mm to 216mm (6" to 8½") diameter holes over a wide range of operating air pressures. This heavy duty hammer is specifically designed for waterwell drilling applications where greater depth requirements demand less air usage with minimal performance loss.

The Hyper 63 is supplied with 3½" api reg pin backhead as standard but other connections are available on request. A positive fitting water check valve guards against ingress of ground water when the air is shut off.

The Hyper 63 Hammer is designed accept Button Bits with a shank and foot valve identical to Ingersoll Rand DHD 360. However The Hyper 63 can also be supplied to accept the Mission SD6 and XL6 type of Button Bits.

COMPONENT PARTS

Ref	Description	Part Number
1	Backhead	HSH633803M
2	Backhead 'O' Ring	HSH6114
3	Check Valve	IPRCV04
4	Check Valve Spring	IPRCVS04
5	Diverter	HSH6120
6	Compression Ring	HSH6128
7	Tube Holder	HSH6131
8	Tube Buffer (2)	HSH6129
9	Control Tube	HSH6330
10	Piston	HSH6103
11	Piston Retaining Ring	HSH6132
12	Bit Retainer Ring	HSH6337093
13	Bit Retainer 'O' Ring	HSH6137A093
14	Chuck	HSH6335093
15	Chuck Release Washers	HSH6326
16	Wearsleeve	HSH6300
17	Guide Bush	HSH6386
18	Guide Bush 'O' Rings (2)	HSH6386A
	Complete Hammer	BR63H01

HAMMER SPECIFICATION

	Imperial	Metric
Weight (less bit)	216 lbs	98.1 Kgs
Length (less bit)	52"	1320 mm
Outside dia.	5.62"	142.8 mm
Piston weight	49 lbs	22.3 Kgs
Stroke	4.25"	108 mm

AIR CONSUMPTION

PSI	BAR	C.F.M	Cu. Mtr / min
150	10.3	339	9.6
200	13.8	522	14.8
250	17.2	730	20.7
300	20.7	958	27.1



Manufacturers of Rock Drilling Equipment
 Turnoaks Business Park, Burley Close, Chesterfield,
 Derbyshire, United Kingdom. S40 2UB
 Tel : +44(0)1246 544700 Fax : +44(0)1246 544701
 Email : info@bulroc.com Web : www.bulroc.com