



# HYPER 51HD DTH HAMMER

Technical Brochure



Certificate No. 2448/00

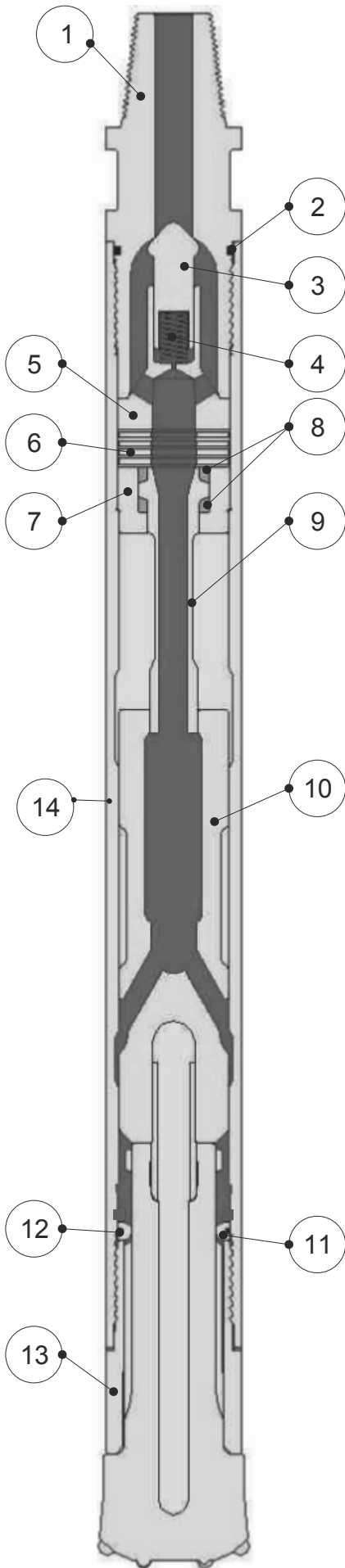

## Hyper 51HD Valveless Hammer 140mm (5.5") - 165mm (6½") dia. Holes

The Hyper 51HD is a valveless DTH hammer designed for drilling 140mm-165mm (5.5" - 6½") dia. Holes.

This heavy duty hammer is specifically designed for drilling through demanding & abrasive rock conditions

The Hyper 51HD hammer is designed to accept as standard button bits with a shank and footvalve identical to the Ingersoll Rand DHD 350R. However, the Hyper 51HD can also be supplied to accept SD5, Mach 50 and QL50 types of button bits.

### COMPONENT PARTS

Ref	Description	Part Number
1	Backhead	HSH513803MHD
2	Backhead 'O' Ring	HSH5114
3	Check Valve	IPRCV03
4	Check Valve Spring	IPRCVS02
5	Diverter	HSH5120
6	Compression Ring	HSH5128
7	Tube Holder	HSH5131
8	Tube Buffer (2)	HSH5129
9	Control Tube	HSH5130
10	Piston	HSH5103
11	Bit Retainer Rings	HSH5137092
12	Bit Retainer 'O' Ring	HSH5137A092
13	Chuck	HSH5135092HD
14	Wearsleeve	HSH5100HD
	<b>Complete Hammer</b>	<b>BR51H01HD</b>

### HAMMER SPECIFICATIONS

	English	Metric
Weight(less bit)	143.66 lbs	65.3 kg
Length (less bit)	43.94"	1116 mm
Outside dia.	4.65"	118 mm
Piston weight	26.8 lbs	12.2 kg
Stroke	4.25"	108 mm

### AIR CONSUMPTION

PSI	BAR	C.F.M.	Cu. Mtr / min
150	10.3	214	6.05
200	13.8	329	9.3
250	17.2	459	13
300	20.7	604	17.1