

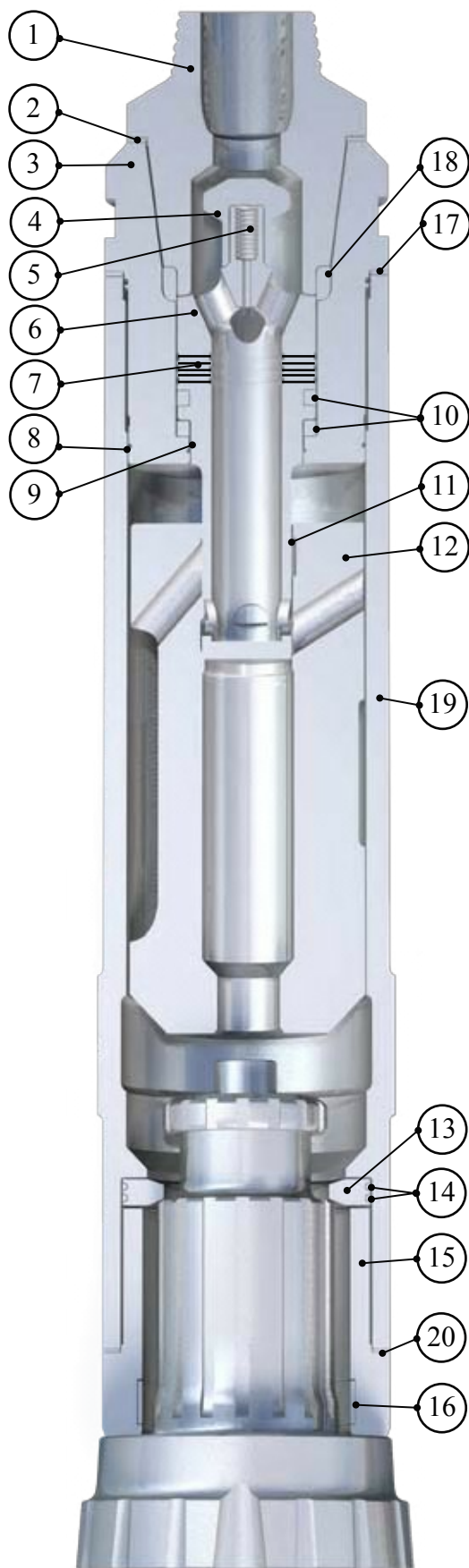

HYPER 241 DTH HAMMER

Technical Brochure





Hyper 241 Valveless Hammer

610mm (24") - 864mm (34") dia. Holes

The Bulroc Hyper 241 hammer is a valveless DTH hammer designed to operate efficiently at pressures ranging from 7 bar to 15 bar (100psi 225psi). The hammer is supplied with an 8 5/8" api reg pin Backhead as standard or an 8 5/8" api reg box thread can be supplied also. A positive seating check valve is fitted and the Hyper 241 is Supplied to suit N240 shank type Button Bits as standard.

Component Parts

Ref	Description	Part Number	Qty
1	Backhead Adaptor 8 5/8" reg Pin	HSH24138AD082M	1
2	Backhead Adaptor Breakout washer	HSH24127	1
3	Backhead	HSH24138	1
4	Check Valve	HSH18108	1
5	Check Valve Spring	HSH24110	1
6	Valve Chest	HSH24104	1
7	Compression Buffer	HSH24128	1
8	Backhead 'O' Ring	HSH24114	1
9	Internal Backhead 'O' Ring	HSH24114A	1
10	Tube Buffers (2)	HSH24129	1
11	Control Tube	HSH24130	1
12	Piston	HSH24103240	1
13	Bit Retaining Ring	HSH24137240	1
14	Bit Retainer 'O' Ring (2)	HSH24137A240	1
15	Chuck	HSH24135240	1
16	Chuck Bearing	HSH24135240BE	1
17	Breakout Washer Backhead	HSH24125	1
18	Internal Washer Adaptor	HSH24106	1
19	Wearsleeve	HSH24100	1
20	Breakout Washer Chuck	HSH24126	1
	Complete Hammer	BR241H01	

Hammer Specification

	Imperial	Metric
Weight (less bit)	5522 lbs	2510 Kg
Length (less bit)	92.7"	2355 mm
Outside dia.	21"	533 mm
Bore dia.	17.02"	433 mm
Piston weight	1276 lbs	580 Kg
Stroke	6.00"	152mm

Air Consumption

PSI	BAR	C.F.M	Cu. Mtr / min
100	6.90	2281	64.6
125	8.60	3188	90.3
150	10.34	4191	118.7
175	12.07	5281	149.5
200	13.80	6452	182.7
225	15.51	7699	218



Manufacturers of Rock Drilling Equipment

Turnoaks Business Park, Burley Close, Chesterfield, Derbyshire, United Kingdom. S40 2UB

Tel : +44(0)1246 544700 Fax : +44(0)1246 544701

Email : info@bulroc.com Web : www.bulroc.com