



HYPER 125/300HF DTH HAMMER

Technical Brochure



Certificate Number 2446/00
ISO9001

Hyper 125/300HF Valveless Hammer 330mm (13") - 445mm (17½") dia. Holes

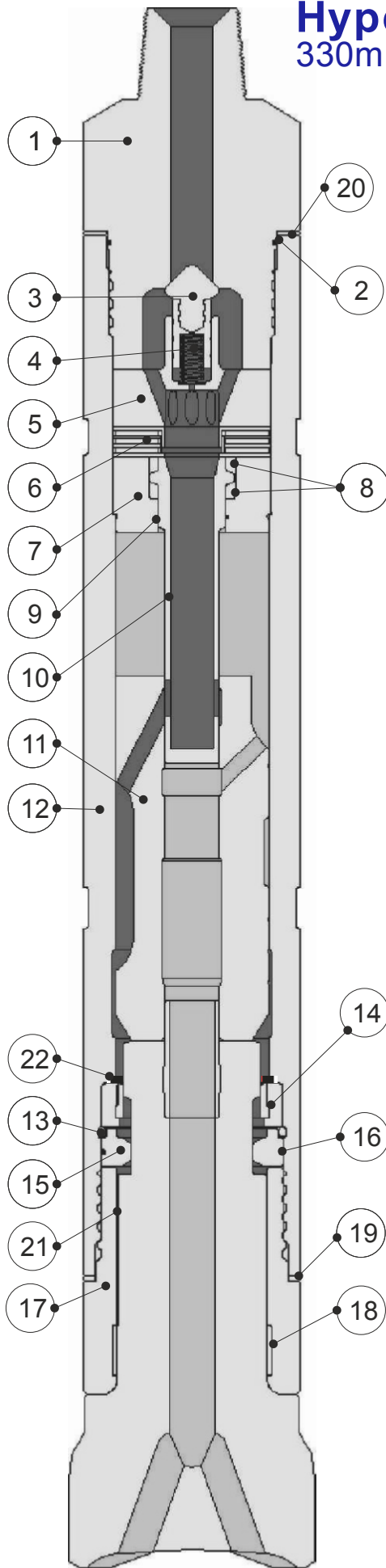

The Bulroc Hyper 125/300HF is designed specifically for drilling shallow holes in soft/medium strata, due to the lighter piston and increased blow rate. The Bulroc Hyper 125/300HF is especially suited to the N125 shank, but other conversions are available on request.

The Bulroc Hyper 125/300HF is fitted with a 6 5/8" API Reg Pin as standard, complete with a positive seating water check valve. The control tube choke is supplied solid as standard.

COMPONENT PARTS

Ref	Description	Part Number
1	Backhead 6 5/8" Reg Pin	HSH1213880M125
2	Backhead 'O' Ring	HSH12114
3	Check Valve	HSH12108
4	Check Valve Spring	HSH12110
5	Diverter	HSH12120
6	Compression Buffer	HSH12128
7	Control Tube Holder	HSH12131
8	Control Tube Buffers (2)	HSH12129
9	Control Tube 'O' Ring	HSH12130A
10	Control Tube	HSH12130
11	Piston	HSH12103125HF
12	Wearsleeve	HSH12100125
13	Guide Bush Retaining Ring	HSH12132125
14	Guide Bush	HSH12187125
15	Bit Retainer (pair)	HSH12137125
16	Bit Retainer 'O' Ring	HSH12137AST
17	Chuck (N125 c/w drive plate slots)	HSH12135125
18	Chuck Bearing	HSH12135125BE
19	Breakout Washer (chuck)	HSH12126125
20	Breakout Washer (backhead)	HSH12125125
21	Drive Plate N125	DP125
22	Piston Retaining Ring	HSH12132
Complete Hammer		BR125H04
Alternative Backhead 6 5/8" Reg Box		HSH121388FHEX125

HAMMER SPECIFICATIONS

	English	Metric
Weight (less bit)	1853 lbs	840 kgs
Length (less bit)	70.39"	1787 mm
Outside dia.	12"	305 mm
Bore dia.	8.5"	216 mm
Piston weight	231 lbs	105 kg
Stroke	5"	127 mm

AIR CONSUMPTION

PSI	BAR	C.F.M.	Cu. Mtr/min.
100	7	611	17.3
150	10.3	1123	31.8
200	13.8	1729	49.0
250	17.2	2416	68.5



Manufacturers of Rock Drilling Equipment

Turnoaks Business Park, Burley Close, Chesterfield, Derbyshire S40 2UB

Tel: +44(0) 1246 544700 Fax: +44(0) 1246 544701

E-mail: info@bulroc.com website www.bulroc.com BROH125_300HF/A 13/11/12