



Patriot® 180 Down Hole Hammer

FEATURES

- Outdistances competitive hammers in both speed and longevity
- Simplified hammer design with less internal components
- Drills at high frequency to provide less vibration and smooth operation
- More efficient design requires less air which equals fuel savings
- Less overall parts promote easier maintenance
- Designed to operate at pressures to 200 PSI (13.6 BAR)
- Ability to drill efficiently against high heads of water
- Plate drive system to eliminate spline wear and galling

AIR CONSUMPTION

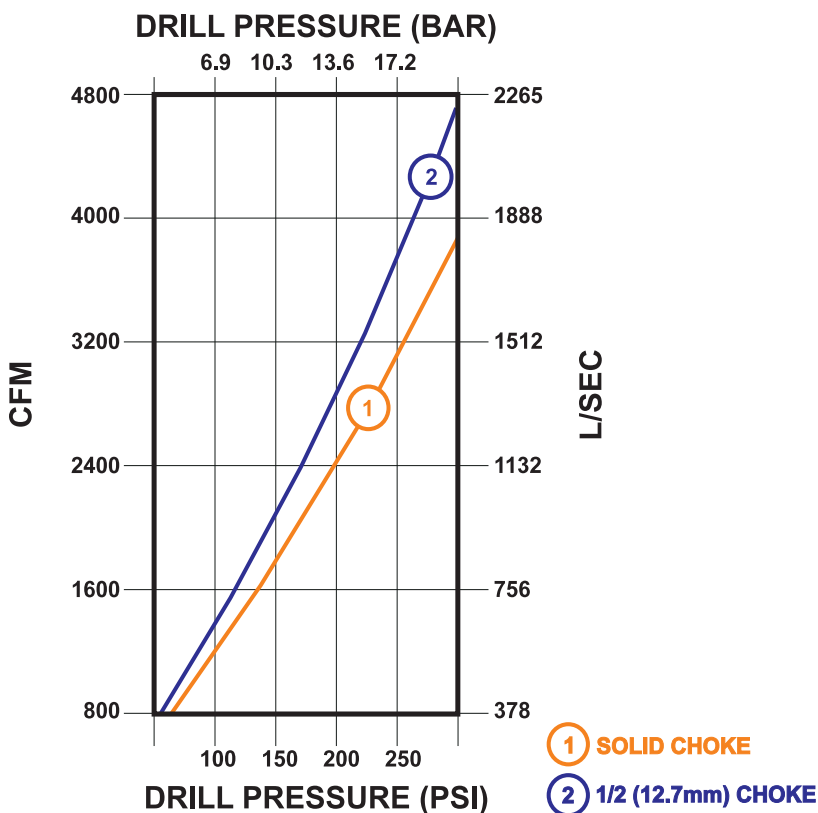

SPECIFICATIONS

Diameter	15-1/2"	394 mm
Bore	13-1/4"	337 mm
Stroke	4-1/2"	114 mm
Weight (Hammer only)	2523 lbs.	1144 kg
Length (Shoulder to Shoulder)	65-15/16"	167 cm
Length (Shoulder to Bit Face)	75-15/16"	193 cm
A.P.I. Reg. Threads	8-5/8	
• 1100 blows per minute at 200 PSI (13.6 Bar)		
• Suitable for drilling holes from 18" to 30" (457 mm to 762 mm) in diameter		
• Accepts C180 bit shank		

Down Hole Button Bits

Patriot® 180

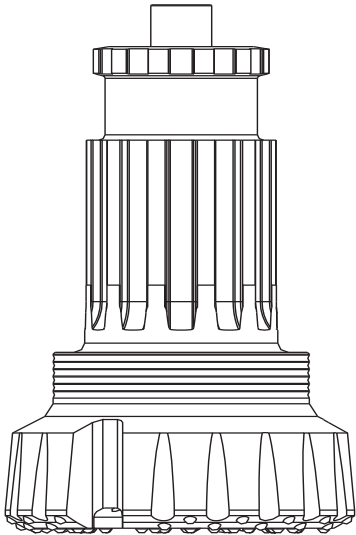

C180 Bit Shank

DIAMETER
inches (millimeters)

WEIGHT*
pounds (kilograms)

FACES AVAILABLE

18"	(457 mm)	1029 lbs.	(468 kg)
20"	(508 mm)	1254 lbs.	(570 kg)
22"	(559 mm)	1347 lbs.	(612 kg)
24"	(610 mm)	1616 lbs.	(735 kg)
26"	(661 mm)	1751 lbs.	(796 kg)
28"	(711 mm)	2007 lbs.	(912 kg)
30"	(762 mm)	2275 lbs.	(1034 kg)

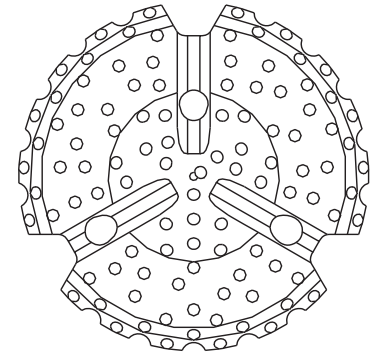

Concave / Flat

* Bit weights are approximate

FEATURES

- Concave or Flat face design for advanced hole cleaning capabilities
- 3/4" (19 mm) diameter carbide buttons throughout face
- Several grades and types of carbide are available
- Significantly larger spline area for exceptional strength and transfer of torque
- Plate drive system for increased spline life
- Side wear buttons are standard on all bits
- Other bit sizes may be available upon request

For More Information Contact:

Bob Lancaster
Northeast USA
(860) 933-1715

Ted Foust
Mid-Atlantic USA
(717) 579-7809

Carl Chidester
Appalachian USA
(304) 203-2408

Jeff Hay
Southeast USA
(478) 279-4834

Virginia Lenox
Western USA
(325) 456-0695

Kathy Wagoner
Oil & Gas
Western USA
(325) 456-0407

Bruce Palmer
U.S. Construction
Latin America
(860) 234-4823

Chris Beare
Europe - Middle East
Africa - India
+44 (0) 7785 934 361

Ian Speer
Australia
+61 (0) 400 077 165