

12"

MACH 142

One piece top-adaptor reduces internal parts. No make up required. External N.R.V. for easy maintenance.

Revised chamber volumes and cycle timing to optimize performance.

Simplified piston geometry for improved balance and location within the cylinder.

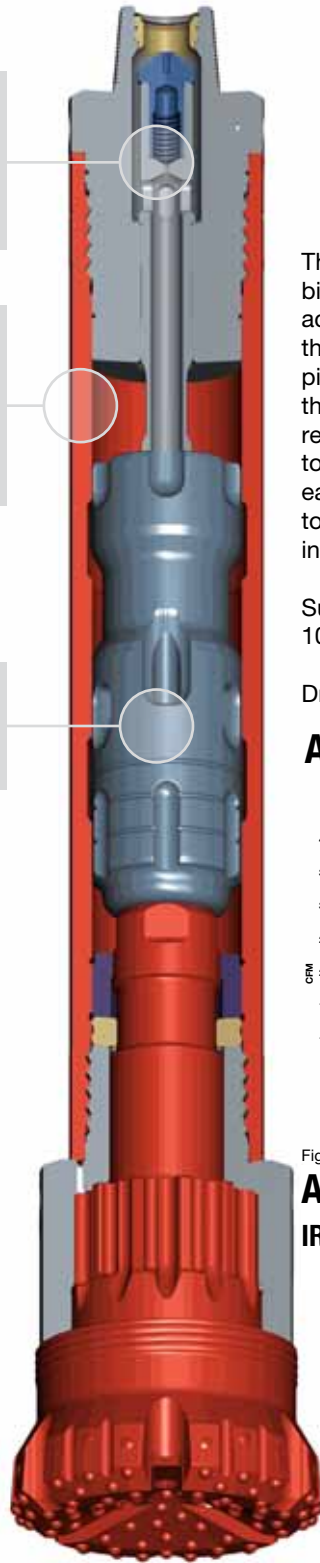

The Mach 142 hammer accepts IR DHD112S shank bits and is equipped with an oversized chuck to accommodate this shank. This oversized chuck protects the cylinder and prolongs its life. This hammer has a pin drive arrangement to prevent metal to metal contact thereby minimising spline wear and damage which can result in drill bit shank failure. Mach 142 has a one piece top-adaptor with N.R.V. (Non-Return-Valve) fitted for easy inspection and service, with integral finger to reduce maintenance and eliminate shimming which increases service intervals.

Suitable for operation at air pressures of 100 - 350 psi (7 - 24 bar).

Drilling diameters of 438 - 660mm (17 1/4 - 26").

Air Consumption

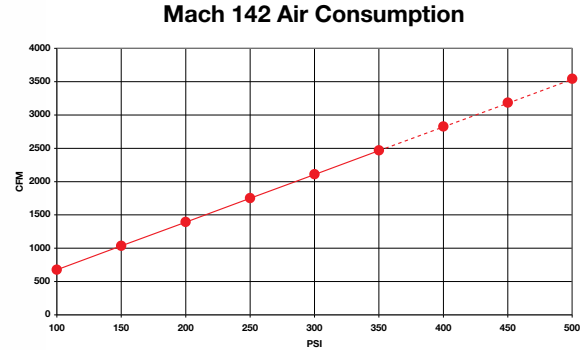

Figures are based on theoretical data

Available Shanks

IR DHD 112S



Hammer Overview

Hammer Type	Mach 142
Part Number	600143
Shank	Ingersoll Rand
	DHD 112S
Top Thread	6 .5/8" Api Reg Pin
Flat Hammer Size	N/A
Weight	688 Kg
Outside Diameter	273mm (10.748")
Make Up Length	1819mm (71.614")
Recommended Minimum Thrust	1600 Kg (3520 Lbs)
Recommended Maximum Thrust	3500 Kg (7700 Lbs)

Parts List

Hammer Type	Mach142	
Shank	DHD112S	
Model Number	600143	
Item	Description	Part Number
1	Lifting Cap	602354
2	Circlip	777001
3	O'Ring	768133
4	N.R.V. Seat	602286
5	Non Return Valve	602288
6	N.R.V. Spring	760055
7	Top-Adaptor	602639
8	O'Ring	768137
9	O'Ring	768137
10	Top-Adaptor Spacer	602366
11	Cylinder	602563
12	Piston	602532
13	Snap Ring	783021
14	Bearing Bush	602531
15	O'Ring	768184
16	Containment Band	603819
17	Bit Retaining Ring	602530
18	Chuck Spacer	602985
19	Drive Pins	600565
20	Chuck	602529
21	End Cap	741037
SK	Service Kit	SK15
RK	Repair Kit	RK24
	Foot Valve	602522
	F/V Tool - Body	602523
	F/V Tool - Pusher	601813

Drill Bits

Part Number	Diameter		Face		Buttons Qty	Over Size	Weight (Kg)
	mm	Inch	Design	Type			
Mach 142/DHD 112S Shank							
650018	438	17.1/4	Concave	Domed	82 x 20mm / 18 x 16mm Wear	Y	354
650964	508	20	Concave	Domed	91 x 20mm / 36 x 16mm Wear	Y	470
650907	610	24	Concave	Domed	123 x 20mm / 66 x 16mm Wear	Y	512
653126	660	26	Convex	Domed	171 x 20mm / 39 x 16mm Wear	Y	600