

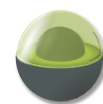

HYPER 66DH QL60 DTH HAMMER

Technical Brochure



Geothermal



Water Well



Certificate Number 2446/00
ISO9001

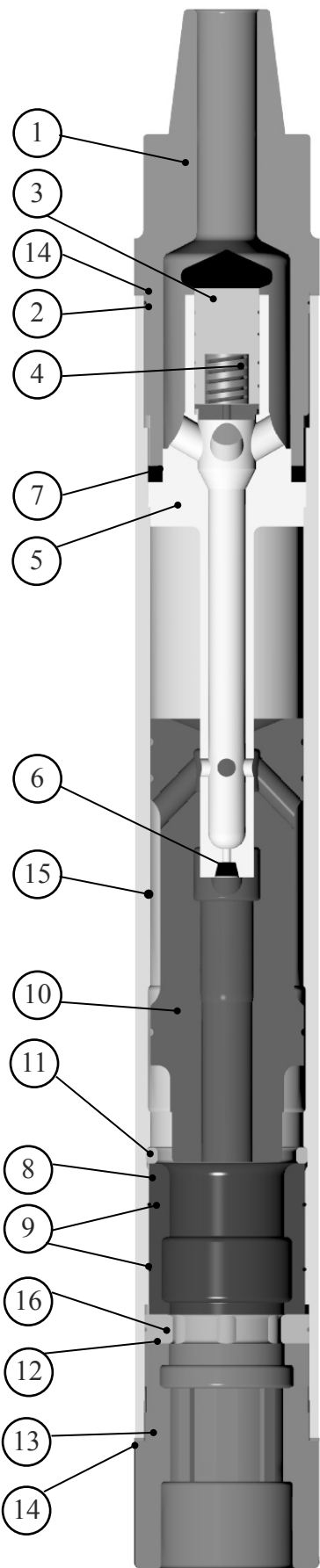

Hyper 66DH / QL60 (Deep Hole) Hammer 152mm (6") 216mm (8½") dia. Holes

The Hyper 66DH is a valveless DTH Hammer specifically designed to operate efficiently at depths and overcome high heads of water. The combined control tube, diverter and check valve minimises the number of component parts, reducing the overall length of the hammer for ease of handling.

The Hyper 66DH is supplied as standard with a 3½" API reg. pin, backhead and a chuck to accept button bits with Ingersoll Rand QL 60 shanks.

Alternatively, the Hyper 66DH can also be supplied with chucks to suit most other major types of button bits including IR DHD 360.

COMPONENT PARTS

Ref	Description	Part Number	Qty
1	Backhead	HSH66DH3803M	1
2	Backhead 'O' Ring	HSH6114	1
3	Check Valve	IPRCV04	1
4	Check Valve Spring	IPRCVS04	1
5	Control Tube	HSH66DH30	1
6	Choke Set	HSH66DH19	1
7	Compression Buffer	HSH66DH22	1
8	Bush	HSH66DH86099	1
9	Bush 'O' Ring	HSH66DH87	2
10	Piston	HSH66DH03099	1
11	Piston Retaining Ring	HSH6132	1
12	Bit Retaining Ring	HSH66DH37099	1
13	Chuck	HSH66DH35099	1
14	Breakout Washer	HSH66DH26	2
15	Wearsleeve	HSH66DH0099	1
16	Bit Retaining 'O' Ring	HSH66DH37A099	1
	Complete Hammer	BR66DH02	

HAMMER SPECIFICATION

	Imperial	Metric
Weight (less bit)	219 lbs	100 Kgs
Length (less bit)	40.90"	1039 mm
Outside dia.	5.620"	142.75 mm
Piston weight	43.5 lbs	20 Kg
Stroke	4.25"	108 mm

AIR CONSUMPTION

PSI	BAR	C.F.M	Cu. Mtr / min
150	10.30	296	8.39
200	13.80	456	12.92
250	17.20	637	18.05
300	20.70	838	23.73
350	24.1	1058	29.98
400	27.6	1290	36.54
430	30.00	1440	40.78



Bulroc (UK) Ltd.

Turnoaks Business Park, Burley Close, Chesterfield, Derbyshire, United Kingdom. S40 2UB

Tel : +44(0)1246 544700 Fax : +44(0)1246 544701

Email : info@bulroc.com Web : www.bulroc.com