



# HYPER 101 DTH HAMMER

Technical Brochure



Certificate No. 2448/00

## Hyper 101 Valveless Hammer 254mm (10") - 305mm (12") dia. Holes

The Bulroc Hyper 101 Hammer is designed to operate over a wide range of operating air pressures. A 6<sup>5</sup>/<sub>8</sub>" API reg. pin backhead is supplied as standard.

The Hyper 101 is fitted with a positive seating water check valve and is supplied as standard fitted with a solid choke.

The Hyper 101 is designed to accept button bits with a shank identical to the Sandvik Mission SD10. However, the Hyper 101 can be supplied to accept the Numa 100 type of button bit.

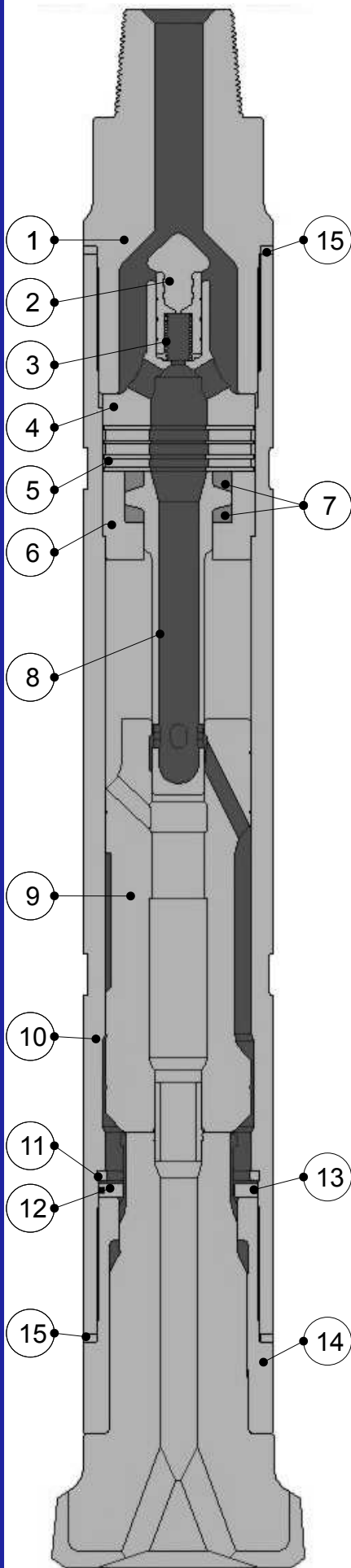

### COMPONENT PARTS

Ref	Description	Part Number
1	Backhead 6 <sup>5</sup> / <sub>8</sub> " reg Pin	HSH1013880M
2	Check Valve	HSH10108
3	Check Valve Spring	HSH10110
4	Diverter	HSH10120
5	Compression Buffer	HSH10128
6	Control Tube Holder	HSH10131
7	Control Tube Buffers (2)	HSH10129
8	Control Tube	HSH10130
9	Piston	HSH10103046
10	Wearsleeve	HSH10100
11	Piston Retaining Ring	HSH10132
12	Bit Retainer Rings	HSH0137046
13	Bit Retainer 'O' Ring	HSH10137A046
14	Chuck	HSH10135046
15	Breakout Washer (2)	HSH10126
	<b>Complete Hammer</b>	<b>BR101H01</b>

### HAMMER SPECIFICATIONS

	English	Metric
Weight (less bit)	745lbs	338 kgs
Length (less bit)	62"	1575mm
Outside dia.	8.860"	225mm
Bore dia.	6.840"	175mm
Piston weight	150lbs	68 kg
Stroke	5"	127mm

### AIR CONSUMPTION

PSI	BAR	C.F.M.	Cu. Mtr / min
100	7	365	10.3
150	10.3	671	19.0
200	13.8	1034	29.3
250	17.2	1445	40.9